

Another possible accessories:



BG
Protection guard



GS
ON-OFF switch



POT 1
Control unit
(electronically)



POT 2
Control unit
(electronically)



POT 3
Steuergerät
(3-stufig)



Wall mounting
 of the tube fan **Type R...G** with foot (MKA)
 Mounting hardware is **not** included!

Step 1
 Installation foot (MKA)

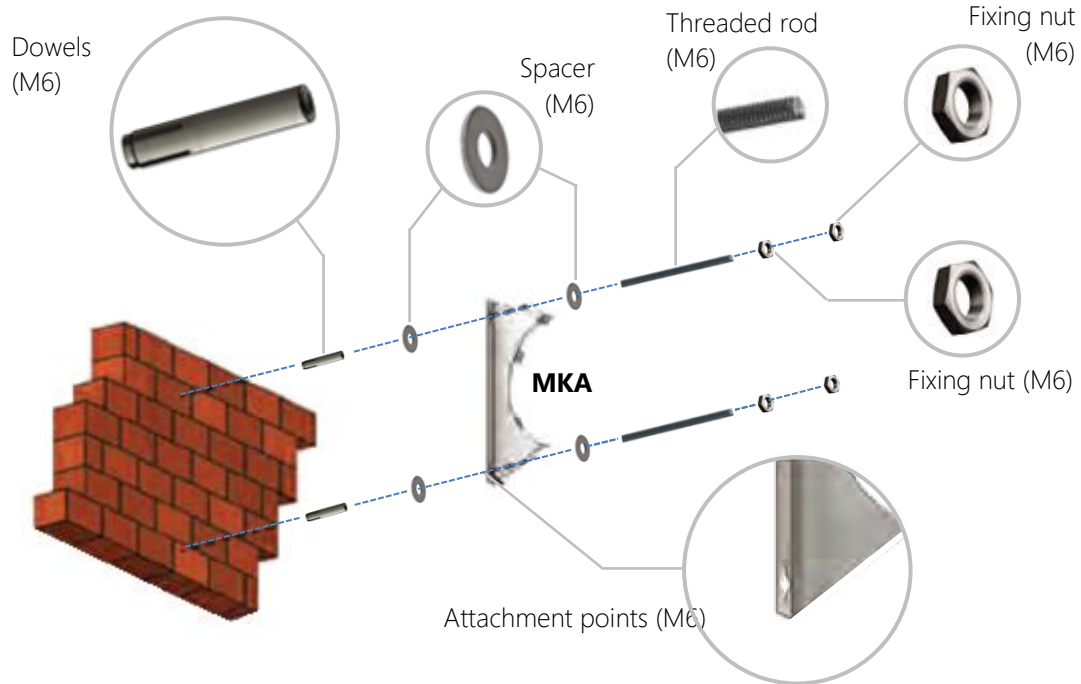

Step 2
 Installation tube fan (R)

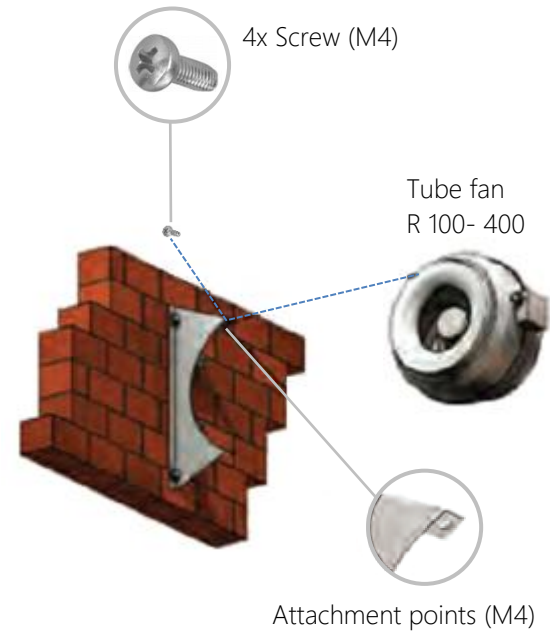



Ceiling mount

of the tube fan **Type R...G** with foot (MKA)
 Mounting hardware is **not** included!

Step 1

Installation foot (MKA)

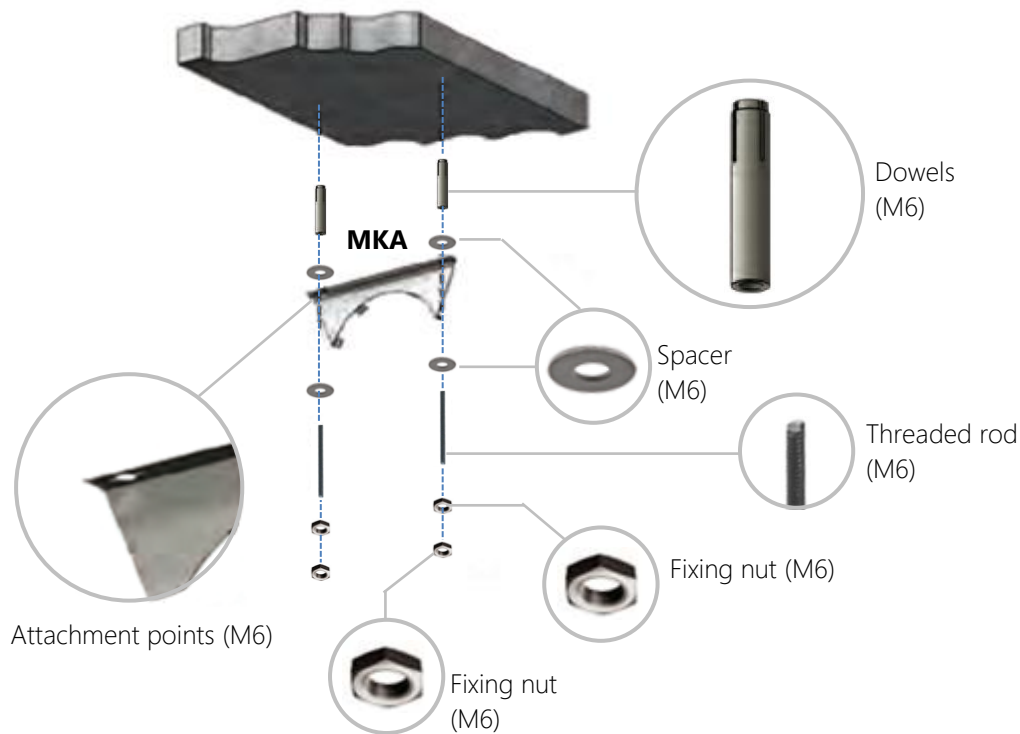

Step 2

Installation tube fan (R)

